



# ENSURING AN ACCURATE RESULT IN AN ANALYTICAL INSTRUMENTATION SYSTEM – PART 3: MAINTAINING A REPRESENTATIVE SAMPLE

By Doug Nordstrom and Tony Waters

The objective of an analytical instrumentation (AI) system is to provide a timely analytical result that is representative of the fluid in the process line at the time the sample was taken. If the AI system alters the sample so the analytical result is changed from what it would have been, then the sample is no longer representative and the outcome is no longer meaningful or useful. Assuming the sample is properly taken at the tap, it may still become unrepresentative under any of the following conditions:

- If deadlegs or dead spaces are introduced at inappropriate locations in the AI system, resulting in a “static leak,” a bleeding or leaking of the old sample into the new sample

- If the sample is altered through contamination, permeation, or adsorption
- If the balance of chemicals is upset due to a partial change in phase
- If the sample undergoes a chemical reaction

This article will review the major issues leading to an unrepresentative sample and provide recommendations on how to avoid a compromised sample. It will discuss deadlegs and dead spaces; component design and placement; adsorption and permeation; internal and external leaks; cross contamination in stream selection; and phase preservation.

## Deadlegs and Dead Spaces

It's important to understand the difference between mixing volumes and deadlegs. They are not quite the same. A mixing volume is a reservoir with a separate inlet and an outlet, such as a filter or knockout pot. Fluid flows through a mixing volume, *slowly*, but it flows. A deadleg is typically a tee formation with a block at the end so there is no through-flow (Figure 1).

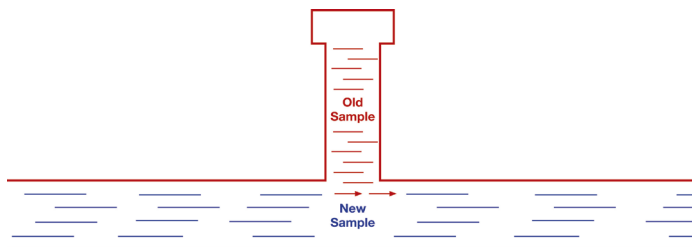

**Figure 1.** In this deadleg configuration, old sample trapped in the tee formation leaks into the main fluid stream, contaminating the new sample.

Examples of deadlegs are pressure gauges, transducers, lab sampling valves, or relief valves. You can calculate the rate at which a mixing volume will flush out an old sample but the same is not true of a deadleg. A deadleg holds the old sample, allowing a small portion of it to mix with the new sample,

contaminating it. Deadlegs may eventually clean up or not. They do not behave in a predictable manner. Generally, deadlegs become more problematic as the ratio of length to diameter increases. In addition, lower flow in the analytical line increases the degree of the deadleg's effect. A pressure gauge with a deadleg volume of 10 cm<sup>3</sup> may not have much effect in high flow, but in low flow (e.g., 30 cm<sup>3</sup>/min) it could – if located in the wrong place – compromise the whole application. Here are some general guidelines concerning deadlegs:

1. Use high flow rates whenever possible
2. Select a component design that minimizes or eliminates deadlegs
3. When installing the component, ensure that the end connection minimizes the length of the deadleg
4. Remove deadlegs to a bypass loop, so only the minimal number of deadleg components are on the direct line with active flow to the analyzer
5. Replace a tee and two-way ball valves with three-way ball valves

In most systems, deadleg components can be positioned so most are not in a direct line with active flow to the analyzer. They may be placed on a bypass loop and will still serve their intended purpose. A bypass loop or a fast loop is a configuration that enables relatively fast flow in a loop, with a return to the process line or to a flare or drain. At one point in the loop, a part of the flow is diverted to the analyzer. Figure 2 shows a system with five deadlegs, whereas Figure 3 shows a variation of this configuration with the following improvements:

- Two pressure gauges are removed to a bypass loop
- One pressure gauge is removed without a replacement
- The calibration gas inlet is moved to the stream selection system
- The lab sample take-off is moved to a flow loop that originates at a filter

When multiple fluid streams are running to the same analyzer by way of a stream selection system, components with deadlegs should, if at all possible, be placed before the stream selection system in a bypass or return line to minimize the opportunity for cross-stream contamination. The same is true of components with “memory,” i.e., components with a lot of surface area (filters) or with permeable materials, like elastomers (e.g., some regulators). For example, rather than locating one filter after the stream selection system, it is better to purchase multiple filters and locate them before the stream selector system, one in each of the multiple lines. Similarly, it is not advisable to locate a lab sample port, with a tee and quick-connect, after the stream selection system because the tee configuration is a deadleg that may cause cross-stream contamination.

The ideal configuration (Figure 4) would locate the lab sample port on a bypass loop – a separate bypass loop for each sample line – before the stream selection system. The lab sample port, gauges, and other deadlegs can be located on the bypass loop, downstream of the point where flow is diverted to the analyzer. An additional advantage to this configuration is that while one stream is running to the analyzer, the other streams continue to flow through their respective bypass loops, keeping the sample current. Components with limited memory, those that can be safely located after the stream selection system, include some high-quality regulators, shutoff valves, check valves, and flow meters. In the case of liquid samples, when there is minimal pressure drop through the analyzer, deadleg components like gauges may be located after the analyzer.

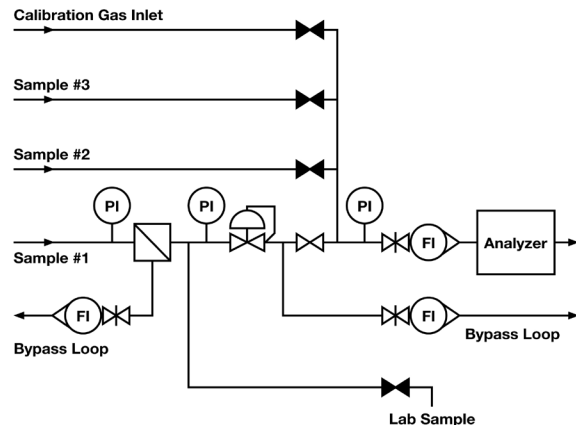

**Figure 2.** Five deadlegs in this configuration pose the risk of contaminating the sample.

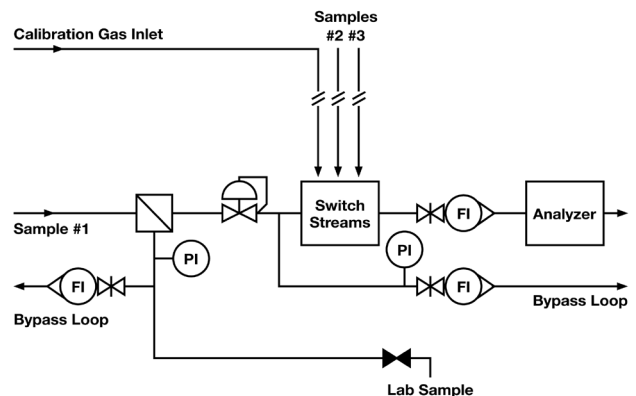

**Figure 3.** A variation of Figure 2, this configuration introduces design improvements that eliminate the deadlegs or move them to locations where they will not have an effect on the analyzer reading.

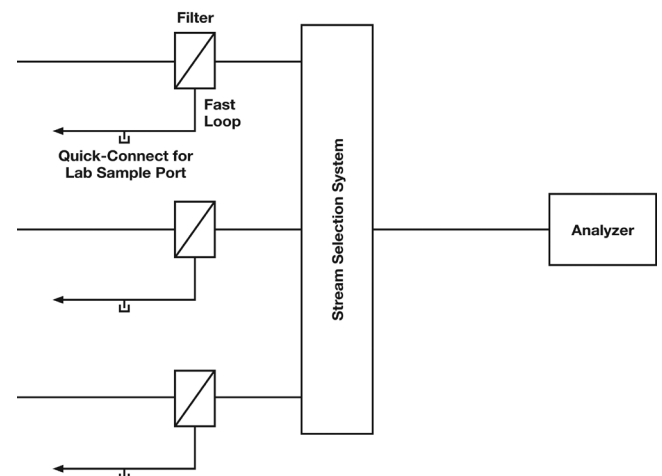

**Figure 4.** Quick-connect lab sample ports are located on bypass loops before the stream selection system. This way they are not creating deadlegs on a line shared by sample streams.



A less subtle point about component placement concerns the use of the double block and bleed (DBB) configuration. This configuration, which consists of two block valves and, in between them, a bleed valve running to a vent, is a well-established standard in the industry – and for good reason: It guards against contamination between fluid streams. It should be used whenever there is an intended block between two fluid streams that must remain separate. The basic premise is that two blocks – shutoff valves – are better than one. DBB is the basis of all stream selector systems. It should also be used when calibration fluid is introduced into a system.

Beyond component placement, there is component selection. Components vary in the amount of dead space they contain. It behooves the system designer to review cutaway drawings and to look for dead space; for example, in a ball valve, around the ball and its packing. The flow path through a valve or through an assembly of components should be smooth, without sharp changes in direction, which cause pressure drop. Purgeability data demonstrates in quantifiable terms that similar components or systems take longer or shorter periods of time to flush out.

In Figure 5, three fluid systems were filled with nitrogen. Then, a second gas was introduced and the period of time required to flush the nitrogen from the components was recorded along the horizontal axis. Note that Geometry 3 does not clean up even after 30 seconds, quite a long period of time in the context of an AI system, when the industry standard for an analytical response is one minute. Geometry 1 performs the best with all nitrogen flushed from the system in less than 5 seconds.

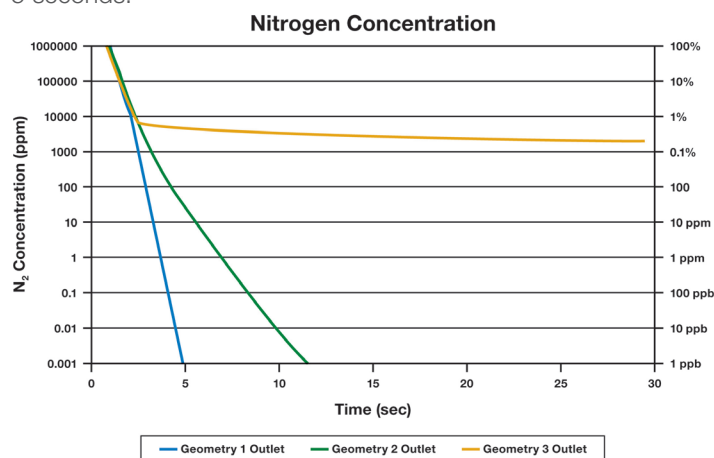

**Figure 5.** Using computation fluid dynamics (CFD), the following experiment was conducted. Three different fluid system configurations were filled with nitrogen. Then, a second gas was introduced. The amount of time required to flush out the nitrogen was recorded along the horizontal axis.

## Leaks and Permeation

All fluid system components leak because no seal is perfect and all materials are subject to permeation, even stainless steel. In many cases, the leak rate is too slow to be significant in an analytical instrumentation system, but in other cases it is not. The engineer and technician should be educated about leak rates and whether they are significant. Quality fluid system components, including valves, are rated to certain temperatures and pressures, and these ratings are published and available. Valves are rated not only for leaks across the seat (internal leaks) but also for shell leaks (external leaks), which are leaks from the inside out. Valves should be able to handle a system's worst-case conditions repeatedly.

Leaks and permeation occur in the direction of lower partial pressure. To determine whether leaks or permeation will be an issue for a system, identify the sample composition and its absolute pressure, and do the same for the atmosphere outside the system. From there, determine partial pressure. For example, if the system media is 100 percent nitrogen at 100 psia, then

the partial pressure of the nitrogen is 100 psia. And if, for simplicity's sake, we say the atmosphere is 80 percent nitrogen and 20 percent oxygen at 15 psia, then the partial pressure will be nitrogen 12 psia and oxygen 3 psia. Given these conditions, oxygen will leak into the system and nitrogen will leak out of the system. Even if the system pressure were increased to 200 psia, 1000 psia or higher, oxygen from the atmosphere would still leak in because the partial pressure for oxygen is greater outside the system than inside the system.

Permeation is not always an issue. A small amount of oxygen leaking into the sample may not matter, depending on the application. When permeation is a potential issue, the system designer should avoid O-rings, elastomers, and PTFE and, instead, employ stainless steel and metal-to-metal seals wherever possible. Another possibility is to enclose the sampling conditioning system or other parts of the system in a nitrogen-purged box.



Some pneumatic valves have design configurations that allow for leaks or permeation between the sample and the actuation air. A valve's actuator may be integral to the valve design, as in miniature modular valves. In other words, the valve body and the actuator are contained in the same block, and they may be separated by only a single seal, such as an O-ring. If this single seal were to fail, molecules from the pneumatic air could leak into the sample, or molecules from the sample may escape into the actuation air. Such leaks may lead to a bad analytical reading or, worse, could cause a fire or an explosion. When employing actuators integral to the valve design, look for valves with double seals as well as safety provisions, such as a vented air gap, which allows air or process leaks to safely escape (Figure 6).

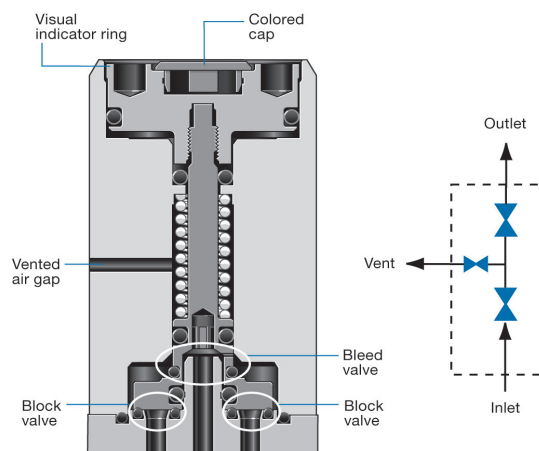

**Figure 6.** In this drawing of a double block and bleed valve, double seals and a vented air gap guard against the possibility of actuation air leaking into the fluid stream.

## Adsorption

Adsorption refers to the tendency of some molecules to stick to solid surfaces, including the insides of tubing. Some molecules, like nitrogen, oxygen, and other “permanent gases,” stick to solid surfaces but are easily knocked off. Other molecules, like water and hydrogen sulfide, stick to tubing and hold tight. If one of these sticky molecules is in the sample, it will stick to the inside surface of the tubing and will not show up in the analytical reading for some time. For example, let's say that we are running pure nitrogen through the tubing but then, after a while, we switch to a sample with a low level of hydrogen sulfide. The hydrogen sulfide will line the insides of the tubing and, as a result, the analytical reading may show no hydrogen sulfide molecules at all. However, once the insides of the tubing have been saturated, hydrogen sulfide will begin to show up in the analytical reading.

Some operators may believe once the insides of the tubing have been saturated, the problem of adsorption has gone away, but this is not true. Let's assume that after the hydrogen sulfide sample, we return to pure nitrogen. Now, the hydrogen sulfide on

the insides of the tubing will begin to jump off so, even though the new sample is pure nitrogen, the analytical reading will show the presence of some hydrogen sulfide molecules. Or, to take another example, suppose the temperature of the tubing increases, as a result of daily changes in the sun's intensity. Higher temperatures give molecules more energy so they leave the walls of the tubing, causing changes in the analytical reading.

If the molecules being measured make up more than 100 ppm in your sample, adsorption will probably not matter a great deal. However, if the molecules being measured make up less than this amount, then the adsorption must be addressed. An electropolished surface on the inside of the tubing or, another solution, PTFE lining, will provide marginal improvements in the adsorption rate. Or, another option is silicon-lined tubing. Manufacturers of this product deposit a very thin coating of silicon on the inside of the tubing. While the product is expensive, the rate of improvement is dramatic. The tubing is still flexible with the silicon lining, although the minimum bending radius is increased.

## Phase Preservation

To maintain a representative sample, one must avoid a partial phase change in the sample. Molecules assume different phases – solids, liquids, or gases or a mixture of these – depending on temperature and pressure in the system. The point at which the phases begin to change for each molecule is different, as represented in phase charts with temperature along one axis and pressure along the other (e.g., Figure 7, a phase chart for water). Solid lines show the interfaces between the phases. An analytical sample usually consists of more than one type of molecule. The objective is to determine the composition of the sample, (i.e., what percent consists of molecule A, what percent consists of molecule B, etc.).

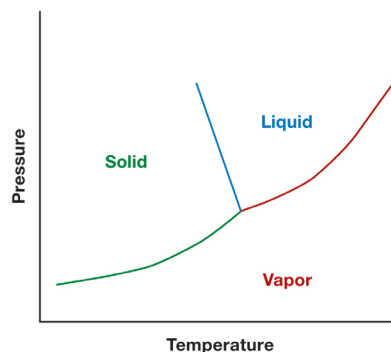

**Figure 7.** The phase change chart shows the points where water changes between a solid, liquid and a gas.



So long as the sample remains all liquid or all gas, the composition will remain the same. However, if we allow a partial phase change of the sample, our composition will change. Figure 8 is a phase chart for a mixture of molecules. The purple line is the bubble-point temperature for the mixture, and the red line is the dew-point temperature of the vapor, or the final boiling point. At any point between these two lines, there will be a two-phase combination of vapor and liquid, and the vapor and liquid will have different compositions. In other words, the sample has fractionated into two different compositions, and the analyzer can no longer determine what the original composition was.

The challenge before the analyzer engineer and technician is to

maintain pressure and temperature in zones that will preserve the entire sample in one phase throughout the analytical system. For a gas sample, the simplest solution is to install a regulator, which will lower the pressure. In addition, if necessary, the sample lines can be heated and maintained at the high temperature with insulated, bundled tubing. Both regulators and bundled tubing are fairly easy components to install and maintain.

For liquid samples, the challenges are somewhat greater. A pump can raise the pressure and, if necessary, chillers may be installed. Unfortunately, neither pumps nor chillers are especially easy components to install and maintain, although they may be necessary.

## Conclusion

Maintaining a representative sample is tricky. There is no alarm that goes off in an analytical system announcing that the sample is unrepresentative. The only way to uncover the problem is to be familiar with the usual tripping-up points. Fortunately, all of them are avoidable or correctable. Most corrective actions come down to:

- Knowing the component design and its limitations (deadlegs, dead spaces, leaking of actuation air)
- Asking the right questions of the fluid system provider (e.g., about valve pressure ratings, cutaway drawings, purgeability data)

- Placing components in the right location in the system (e.g., in the bypass loop, on one side or the other of the stream selection system)
- Determining/calculating whether leaks, permeation, or adsorption will happen or matter (based on partial pressure)
- Knowing which materials or designs will prevent leaks, permeation, adsorption
- Calculating and maintaining the proper pressure and temperature for phase preservation, based on phase charts

## Notes

1. For more on mixing volumes, see Part 1 in this series: "Understanding and Measuring Time Delay."

## Resource

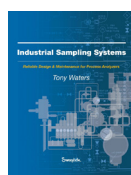

For more information, see the Swagelok book *Industrial Sampling Systems* (2013), the definitive sampling systems reference guide by expert Tony Waters.

## Author Biographies

**Doug Nordstrom** is product manager for general industrial valves for Swagelok Company, focusing on advancing the company's involvement and success with valves sold into the oil and gas, chemical, refining, power, and general industry market segments. He previously worked as the pressure regulator product manager, chemical market manager, and in new product development for Swagelok and earned a number of Swagelok patents in products, including the Swagelok® stream selector valve (SSV) and modular platform components (MPC). Nordstrom graduated with a bachelor's degree in mechanical engineering from Case Western Reserve University and earned a master's degree in business administration from Kent State University

**Tony Waters** has 45 years' experience with process analyzers and their sampling systems. He has worked in engineering and marketing roles for an analyzer manufacturer, an end-user, and a systems integrator. He founded three companies to provide specialized analyzer services to the process industries and is an expert in the application of process analyzers in refineries and chemical plants. Waters is particularly well known for process analyzer training courses that he has presented in many of the countries of Asia, Europe, and the Middle East, as well as North and South America. His presentations are always popular and have equal appeal to engineers and maintenance technicians.